

DXN MARKETING PLAN

Definition of Terms

PV	: Point Value, for qualification and status.
SV	: Sales Value, for calculation of Bonus and Incentive.
Personal Point Value (PPV) / Personal Sales Value (PSV)	: Total PV/SV generated from all personal cash bills transacted in a month.
Personal Group Point Value (PGPV) / Personal Group Sales Value (PGSV)	: Total PV/SV generated in a month by all downline distributors within personal group (ie. excluding breakaway QSAs) and own PPV/PSV.
Diamond Group Point Value (DGPV) / Diamond Group Sales Value (DGSV)	: Total PV/SV generated in a month by all downline distributors within your diamond group (ie. excluding breakaway QSDs) and own PPV/PSV.
Qualified Star Agent (QSA)	: Any SA who maintains 50 PPV and 180 PGPV in a month.
Qualified Star Diamond (QSD)	: Any Diamond who qualifies for 37% Star Group Bonus.
Travel Seminar Qualifier	: Any SA and above who meets the Yearly Travel Seminar Incentive Points (TSIP) Quota set for the year.

Introduction of Remuneration

1) Retail Profit -----	15% - 25%
2) Bonus (71%) and Cash Incentive (AUD3,225)	
a) Group Bonus -----	6% - 21%
b) Star Group Bonus -----	25% - 37%
c) Development Bonus -----	15%
d) International Profit Sharing -----	2%
e) Leadership Bonus -----	15%
f) Travel Seminar Incentive -----	2%
g) One Time HP Cash Incentive -----	AUD 425
h) One Time Oversea Trip Cash Incentive -----	AUD 2,800

Status

Status	Condition
Distributor	Membership Fee Age 18 years + and a sponsor.
Star Agent (SA)	Achieves accumulated Group Sales of 2,250PV
Star Ruby (SR)	Sponsors 3 First Generation Star Agents (SA)
Star Diamond (SD)	With 6 First Generation Star Agents (SA) & qualifies for 37% Star Group Bonus.
Senior Star Diamond (SSD)	Star Diamond who sponsors 2 Star Diamonds *
Double Diamond (DD)	Star Diamond who sponsors 4 Star Diamonds *
Triple Diamond (TD)	Star Diamond who sponsors 6 Star Diamonds *
Gold Diamond (GD)	Star Diamond who sponsors 8 Star Diamonds *
Crown Diamond (CD)	Star Diamond who sponsors 10 Star Diamonds *
Senior Crown Diamond (SCD)	Star Diamond who sponsors 12 Star Diamonds *
Double Crown Diamond (DCD)	Star Diamond who sponsors 14 Star Diamonds *
Triple Crown Diamond (TCD)	Star Diamond who sponsors 16 Star Diamonds *
Gold Crown Diamond (GCD)	Star Diamond who sponsors 18 Star Diamonds *
Crown Ambassador (CA)	Star Diamond who sponsors 20 Star Diamonds *

* As per dynamic compression.

Remuneration in DXN Marketing Plan

1. Retail Profit (15% - 25%)

Direct profit for distributors is when they sell DXN products to non-DXN members. Retail profit is the difference between distributor price and retail price.

2. Group Bonus (6% - 21%)

To be entitled for this Group Bonus, you need to maintain 50 PPV each month.

Accumulated Group PV	Bonus
2,250 and above	21% *
1,625	18%
1,000	15%
500	12%
150	9%
50	6%

* If a Star Agent (21%) maintains 50 PPV and 180 PGPV **, he will become a Qualified Star Agent (25%).

3. Star Group Bonus (25% - 37%)

*To be entitled for this Star Group Bonus, you must be a SA and maintain 50 PPV and 180 PGPV ** (QSA).*

No. of SA (1st Generation)	No. of Qualified SA Lines	DGPV	Bonus
6	-	2,500	37%
	4	1,250 #	
5	-	1,500	35%
	4	1,000	
4	4	-	33%
3	3	-	31%
2	2	-	29%
1	1	-	27%
0	0	-	25%

** PGPV is inclusive of personal PV (i.e. 50 PPV + 130 non-QSA group PV).

For SSD and above, if the number of QSD is more than one, then the DGPV can be borrowed from one of the QSD and the number of QSD will be reduced by one.

4. Development Bonus (15%)

*To be entitled for this Development Bonus, you must be a SA and maintain 50 PPV and 180 PGPV ** (QSA).*

Level of Qualified SA	Bonus
1st Level	5%
2nd Level	4%
3rd Level	3%
4th Level	2%
5th Level	1%

** PGPV is inclusive of personal PV (i.e. 50 PPV + 130 non-QSA group PV).

5. International Profit Sharing (2%)

To be entitled for this International Profit Sharing (IPS) you must be a Qualified Star Diamond (QSD).

IPS Fund = Overall Company's Sales in SV X 2%
--

Your IPS entitlement

=	IPS Fund	X	$\frac{\text{Your IPS Point for the month}}{\text{Total IPS Point for all Qualified Star Diamond and above}}$
---	----------	---	---

• Your IPS Point calculation:

Level of Qualified SD	IPS Point			
Personal			DGSV	X 100%
1st Level QSD (L1)	+	L1	DGSV	X 50%
2nd Level QSD (L2)	+	L2	DGSV	X 40%
3rd Level QSD (L3)	+	L3	DGSV	X 30%
4th Level QSD (L4)	+	L4	DGSV	X 20%
5th Level QSD (L5)	+	L5	DGSV	X 10%

6. Leadership Bonus (15%)

To be entitled for this Leadership Bonus, you must be a Qualified Star Diamond (QSD).

No. of Qualified SD Lines	1	2	3	4	5	6	7	8	9	10
1st Level QSD's DGSV	5%	5%	5%	5%	5%	5%	5%	5%	5%	5%
2nd Level and below QSD's DGSV (till 1st level of next qualifier)	-	3%	4.8%	5.8%	6.5%	7.1%	7.6%	8%	8.3%	8.5%
Minimum DGSV needed to Guarantee upline ('000)	1.25	2.5	3.75	5	5	5	5	5	5	5

No. of Qualified SD Lines	11	12	13	14	15	16	17	18	19	20
1st Level QSD's DGSV	5%	5%	5%	5%	5%	5%	5%	5%	5%	5%
2nd Level and below QSD's DGSV (till 1st level of next qualifier)	8.7%	8.9%	9.1%	9.3%	9.5%	9.6%	9.7%	9.8%	9.9%	10%
Minimum DGSV needed to Guarantee upline ('000)	5	5	5	5	5	5	5	5	5	5

7. Travel Seminar Incentive (2%)

This Travel Seminar Incentive(TSI) shall be used by the qualifier for the travel seminar organised by the Company only. It is not exchangeable for cash and also not transferable. A qualifier may claim up to maximum Travel Seminar Fare against his/her TSI for two(2) if married.

$$\text{Travel Seminar Incentive Fund} = \text{Company's Annual Sales in SV} \times 2\%$$

• To be shared as below:

- i) 50% of the Travel Seminar Incentive Fund (TSIF) to be shared amongst all SA and above who met the YEARLY TSIP QUOTA set for the year.
- ii) 50% of the Travel Seminar Incentive Fund (TSIF) to be shared amongst all SD and above who met the YEARLY TSIP QUOTA set for the year.

a) Travel Seminar Incentive for SA Qualifier (TSI_{SA})

$$\text{TSI}_{\text{SA}} = 50\% \times \text{TSIF} \times \frac{\text{Accumulated TSIP* for a SA Qualifier}}{\text{Total Accumulated TSIP for all SA Qualifiers}}$$

* Travel Seminar Incentive Point (TSIP) will be calculated monthly based on the following formula and to be accumulated for a year:

Level of Qualified SA	Monthly Travel Seminar Incentive Point (TSIP)				
Personal			PGSV	X	100%
1st Level QSA (L1)	+	L1	PGSV	X	50%
2nd Level QSA (L2)	+	L2	PGSV	X	40%
3rd Level QSA (L3)	+	L3	PGSV	X	30%
4th Level QSA (L4)	+	L4	PGSV	X	20%
5th Level QSA (L5)	+	L5	PGSV	X	10%

b) Travel Seminar Incentive for SD Qualifier (TSI_{SD})

$$\text{TSI}_{\text{SD}} = 50\% \times \text{TSIF} \times \frac{\text{Accumulated TSIP* for a SD Qualifier}}{\text{Total Accumulated TSIP for all SD Qualifiers}}$$

* Travel Seminar Incentive Point (TSIP) will be calculated monthly based on the following formula and to be accumulated for a year:

Level of Qualified SD	Monthly Travel Seminar Incentive Point (TSIP)				
Personal			DGSV	X	100%
1st Level QSD (L1)	+	L1	DGSV	X	50%
2nd Level QSD (L2)	+	L2	DGSV	X	40%
3rd Level QSD (L3)	+	L3	DGSV	X	30%
4th Level QSD (L4)	+	L4	DGSV	X	20%
5th Level QSD (L5)	+	L5	DGSV	X	10%

8. Hand Phone Cash Incentive (AUD425) - One Time Only

When you have 3 immediate SA who achieved 3,000 Accumulated GPV, then you will be entitled to receive this **One Time** Hand Phone Cash Incentive amounting to AUD425.

* Only personally sponsored downlines counted.

9. Oversea Trip Cash Incentive (AUD2,800) - One Time Only

When you have 5 immediate downlines who have received their Hand Phone Cash Incentive, then you will be entitled to receive this **One Time** Oversea Trip Cash Incentive amounting to AUD2,800.

* Only personally sponsored downlines counted.

Explanation On The DXN Marketing Plan Reward

1. Retail Profit (15% - 25%)

Direct profit for distributors is when they sell DXN products to non-DXN members. Retail profit is the difference between distributor price and retail price.

Example:

If you sell one unit of DXN Product to a non-DXN member, you will earn the retail profit as below:

One unit of DXN Product	
Distributor Price	AUD14.85
Retail Price	AUD17.80

Therefore,

Retail Price – Distributor Price = Retail Profit

$$\text{AUD}17.80 - \text{AUD}14.85 = \text{AUD}2.95$$

YOUR retail profit is AUD2.95 (19.8% from distributor's price)

Minimum monthly Personal PV required for bonus entitlement (50PV).

* Example 1

Products	PV	SV
Product A	25	25
Product B	25	25
TOTAL	<u>50</u>	<u>50</u>

* Assume 1PV = 1SV for all the following Bonuses and Incentives calculations.

2. Group Bonus (6%-21%)

CASE 1

If in the first month you have acquired 50PV and sponsored 3 new distributors with 250PV each:

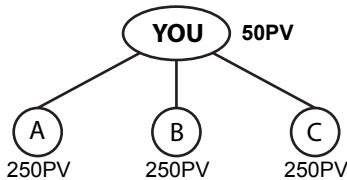

Personal PV/SV (PPV/PSV) = 50PV/SV
 Personal Group PV/SV (PGPV/PGSV) = 800PV/SV

Your Group Bonus = (800SV X 12%) - (250SV X 9%)
 - (250SV X 9%) - (250SV X 9%)
 = AUD96 - AUD22.50 - AUD22.50 - AUD22.50
 = AUD28.50

Therefore:

Your Group Bonus is AUD28.50 and Group Bonus for A,B and C is AUD22.50 each.

CASE 2

If YOU have acquired 30PV and each one of your downline achieved 250PV;

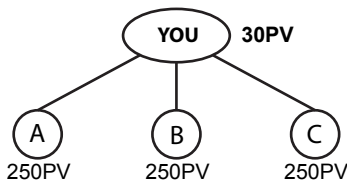

Personal PV/SV (PPV/PSV) = 30PV/SV
 Personal Group PV/SV (PGPV/PGSV) = 780PV/SV

You are not qualified to receive any bonus because your Personal PV is less than 50PPV. To qualify for Group Bonus, YOU must have a minimum of 50PPV.

3. Star Group Bonus (25% - 37%)

CASE 1

If YOU are a Star Ruby (SR) and have sponsored 3 Star Agents (SA) and 2 distributors;

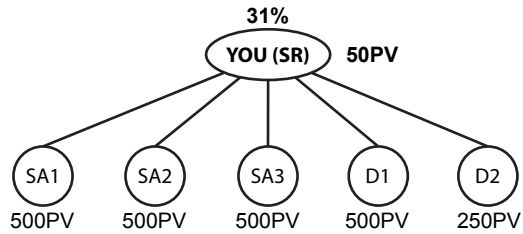

Personal PV/SV (PPV/PSV) = 50PV/SV

Personal Group PV/SV (PGPV/PGSV) = 800PV/SV

$$\begin{aligned}
 \text{Your Star Group Bonus} &= (2,300\text{SV} \times 31\%) - (500\text{SV} \times 25\%) \\
 &- (500\text{SV} \times 25\%) - (500\text{SV} \times 25\%) \\
 &- (500\text{SV} \times 12\%) - (250\text{SV} \times 9\%) \\
 &= \text{AUD}713 - \text{AUD}125 - \text{AUD}125 \\
 &- \text{AUD}125 - \text{AUD}60 - \text{AUD}22.50 \\
 &= \underline{\underline{\text{AUD}255.50}}
 \end{aligned}$$

Therefore:

YOUR Star Group Bonus is AUD255.50.

SA1, SA2 and SA3 will earn AUD125.00 each.

Group Bonus for D1 is AUD60 and D2 is AUD22.50.

CASE 2

If YOU are a Star Diamond with **6 SA** (1st Generation), 50PPV and 250 PGPV.
 At the same time, YOU have some downlines with the status of Star Ruby (SR) and Star Agent (SA) who have at least 50PPV.

The Star Group Bonus entitlement (%) for YOU and your downlines will be as follow:

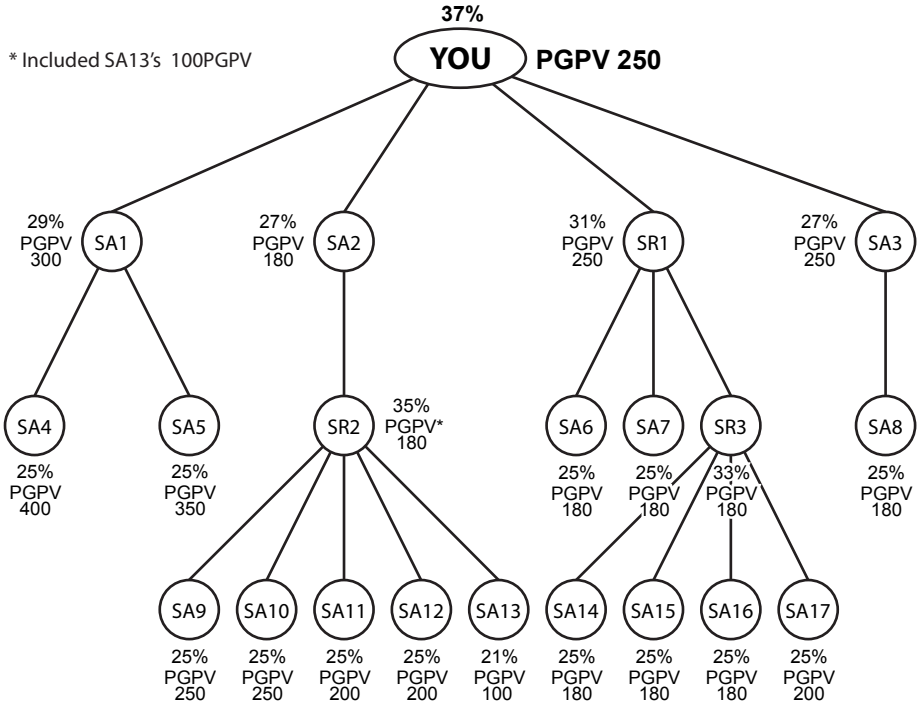

Star Group Bonus (%)

	Status	No of Qualified SA Lines	PPV	PGPV	DGPV	SGB entitlement (%)
YOU	SD	4	50	250	4,520	37%
SA1	SA	2	50	300		29%
SA2	SA	1	50	180		27%
SR1	SR	3	50	250	1,530	31%
SR2	SR	4	50	180	1,080	35%
SR3	SR	4	50	180	920	33%
SA4	SA	0	50	400		25%
SA13	SA	0	50	100		21%

CASE 3

If YOU are a Star Ruby with **5 SA** (1st Generation), 50PPV and 250PGPV.
 At the same time, YOU have downlines with the status of Star Ruby (SR) and Star Agent (SA).
 Some of the SR or SA are inactive (i.e. SA1, SA2, SA5 & SR).

* Included SA4's 100PGPV

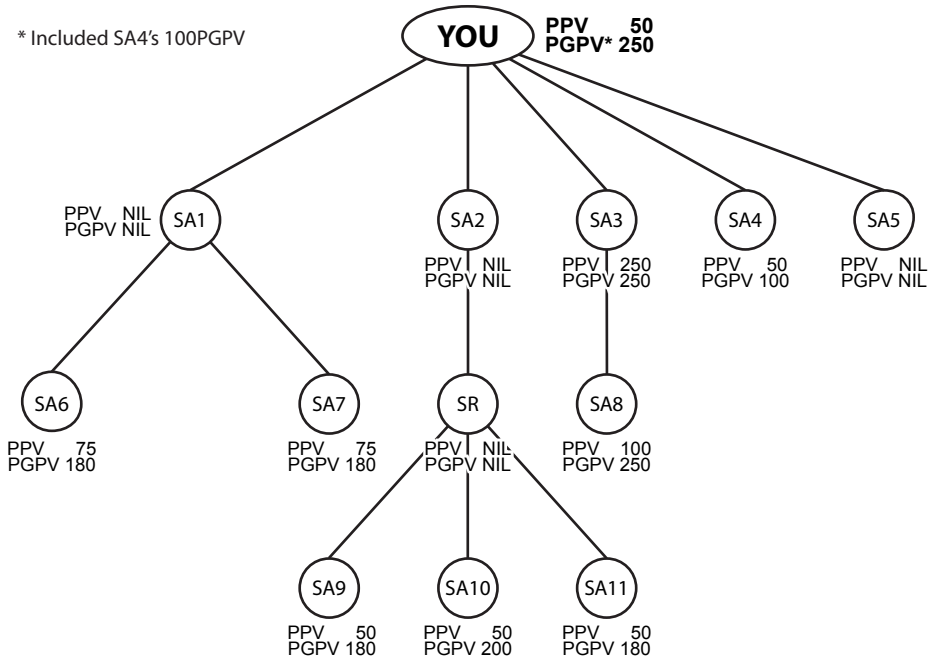

Therefore, YOU are entitled to 35% of Star Group Bonus even you have only 3 qualified SA lines. It is because YOU have 5 SA (1st Generation) and obtained 1,670 DGPV.

4. Development Bonus (15%)

CASE 1

For Development Bonus, if YOU are a Star Ruby (SR) and have downlines as below:

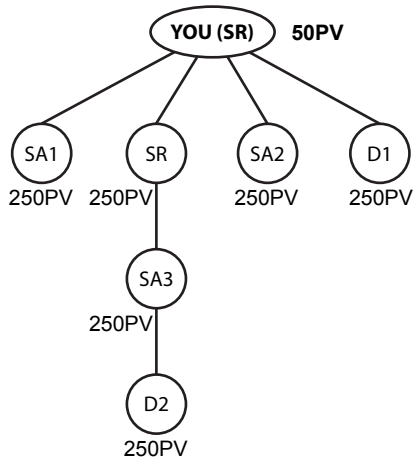

Personal PV/SV (PPV/PSV) = 50PV/SV
Personal Group PV/SV (PGPV/PGSV) = 300PV/SV

YOUR Development Bonus = $(750SV \times 5\%) + (500SV \times 4\%)$
= AUD37.50 + AUD20
= AUD57.50

Therefore:

YOUR Development Bonus is AUD57.50

CASE 2

For Development Bonus, if YOU are a Star Ruby (SR) and have downlines as below:

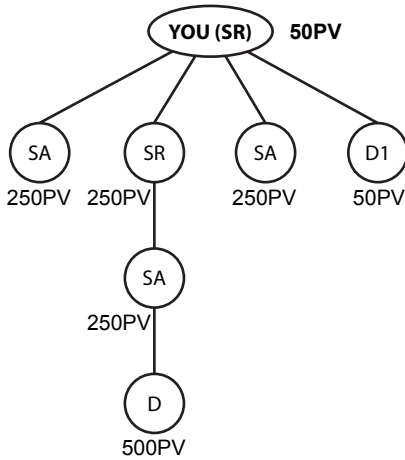

Personal PV/SV (PPV/PSV) = 50PV/SV

Personal Group PV/SV (PGPV/PGSV) = 100PV/SV

YOU are not qualified to earn the development bonus because your Personal Group PV is less than 180PV.

5. International Profit Sharing (2%)

EXAMPLE

YOU are a Senior Star Diamond (SSD) and have downlines of Star Diamond (SD) and above.

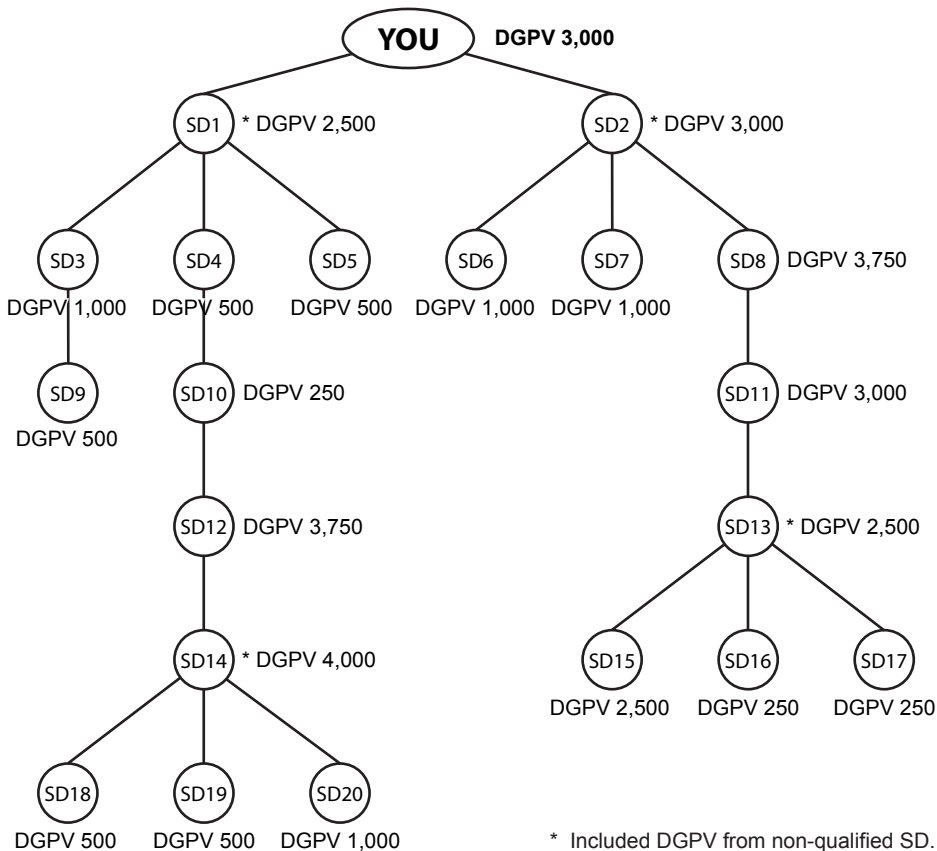

* Included DGPV from non-qualified SD.

Non-qualified SD: SD3, SD4, SD5, SD6, SD7, SD9, SD10, SD16, SD17, SD18, SD19 & SD20
 Qualified SD : YOU, SD1, SD2, SD8, SD11, SD12, SD13, SD14 & SD15

Assumptions:-

- i) 1 PV equals to 1 SV.
- ii) There are 68 Star Diamonds and above in the company and the Total IPS Point is 250,000 points.
- iii) Total company's sales for that particular month is 1,000,000 SV.

IPS Point for YOU:

	DGSV		IPS points
YOU	3,000	X 100%	= 3,000
1st Level: SD1 + SD2	5,500	X 50%	= 2,750
2nd Level: SD12 + SD8	7,500	X 40%	= 3,000
3rd Level: SD14 + SD11	7,000	X 30%	= 2,100
4th Level: SD13	2,500	X 20%	= 500
5th Level: SD15	2,500	X 10%	= 250

YOUR Total IPS Point

11,600

Therefore:

YOUR International Profit Sharing

$$= 2\% \times 1,000,000\text{SV} \times \frac{11,600\text{pts}}{250,000\text{pts}}$$

$$= \underline{\underline{\text{AUD}928.00}}$$

6. Leadership Bonus (15%)

CASE 1

YOU are a Senior Star Diamond (SSD) and have qualified for 37% Star Group Bonus.
 Every Circle (from A1 to C6) represents a SD and above.
 All SDs have qualified for 37% Star Group Bonus.

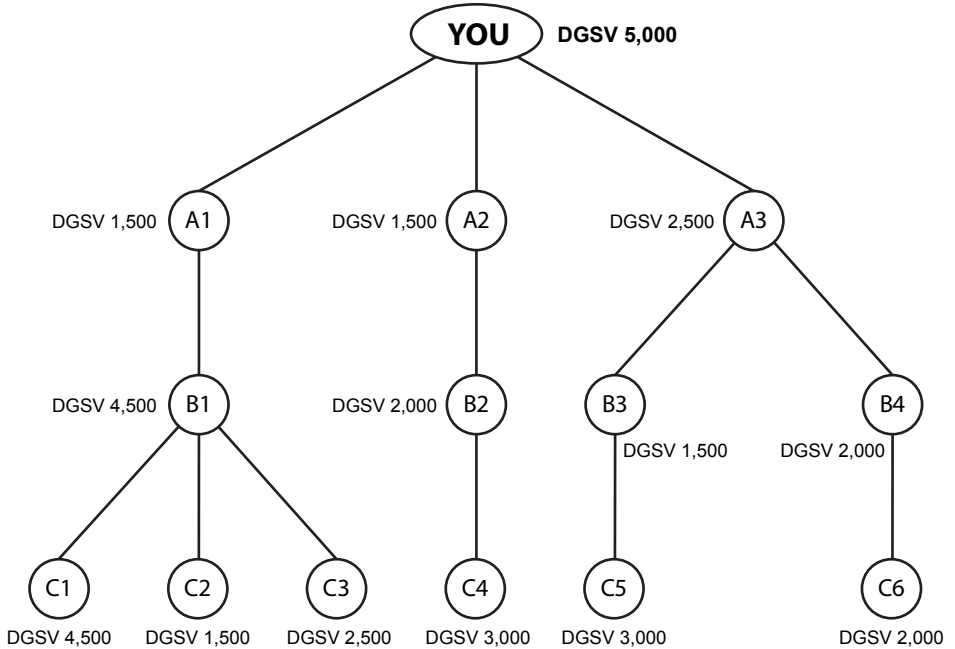

YOUR Leadership Bonus:

1st Level qualified SD:

$$A1 + A2 + A3 = 5,500SV \times 5.0\% = \text{AUD } 275$$

2nd Level and below qualified SD:

$$B1 + C1 + C2 + C3 + B2 + C4 + B3 + B4 = 21,500SV \times 4.8\% = \text{AUD } 1,032$$

$$C5 + C6 = 5,000SV \times 1.8\% = \text{AUD } 90$$

YOUR Leadership Bonus

AUD1,397

CASE 2

YOU are a Double Diamond (DD) and have qualified for 37% Star Group Bonus.
 Every Circle (from A1 to C6) represents a SD and above.
 All SDs have qualified for 37% Star Group Bonus with the exception of A1, A2, A5, & B5.

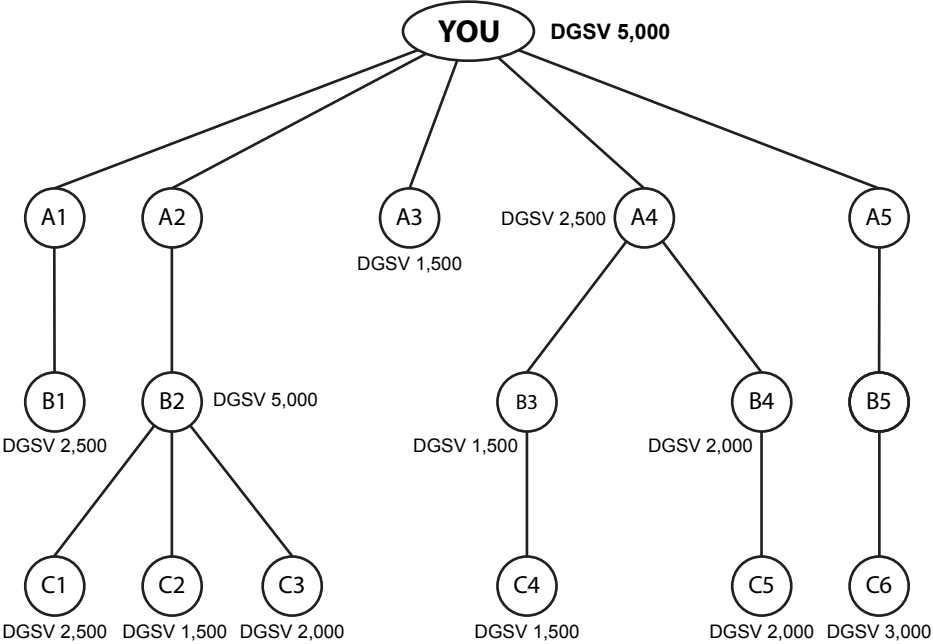

YOUR Leadership Bonus:

1st Level qualified SD:
 B1 + B2 + A3 + A4 + C6 = 14,500SV X 5.0% = AUD 725.00

2nd Level and below qualified SD:
 C1 + C2 + C3 + B3 + B4 = 9,500SV X 6.5% = AUD 617.50
 C4 + C5 = 3,500SV X 3.5% = AUD 122.50

YOUR Leadership Bonus AUD1,465.00

CASE 3

YOU are a Double Diamond (DD) and have qualified for 37% Star Group Bonus.
 Every Circle (from A1 to C6) represents a SD and above.
 All SDs have qualified for 37% Star Group Bonus with the exception of A1, A2, A5, & B5.

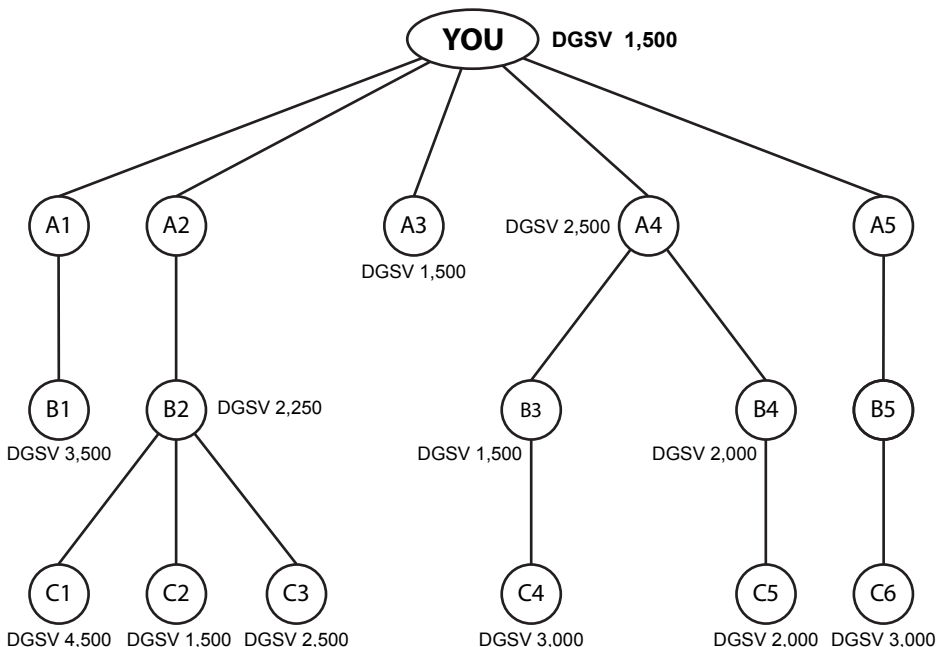

YOUR Leadership Bonus:

1st Level qualified SD:

B1 + B2 + A3 + A4 + C6

Add: Guarantee from Downline (B2)

Less: Guarantee Upline (YOU)

	12,750SV	
	1,500SV	
	<u>(3,500SV)</u>	
	<u>10,750SV</u>	X 5.0%
		= AUD 537.50

2nd Level and below qualified SD:

C1 + C2 + C3 + B3 + B4

Less: Guarantee Upline (B2)

	12,000SV	
	<u>(1,500SV)</u>	
	<u>10,500SV</u>	X 6.5%
		= AUD 682.50

C4 + C5

YOUR Leadership Bonus

	<u>5,000SV</u>	X 3.5%	= AUD 175.00
			<u>AUD1,395.00</u>

* YOU need to guarantee upline 5,000 DGSV.

* B2 need to guarantee upline 3,750 DGSV.

CASE 4

YOU are a Crown Ambassador (CA) and have 20 first generation Crown Ambassadors (CAs) with 5,000 DGSV each. All CAs have 20 Qualified SDs with 5,000 DGSV each.

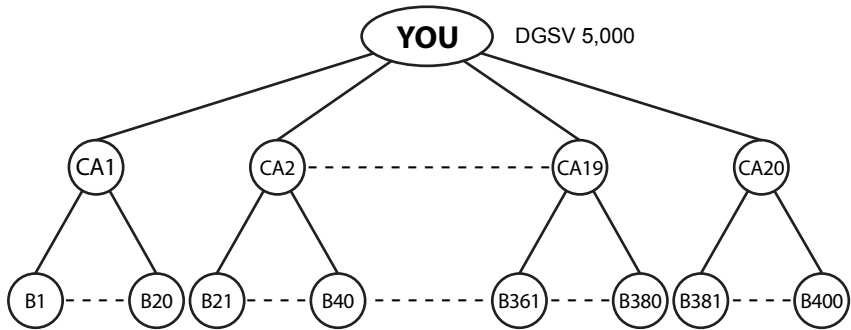

Therefore:

Your Leadership Bonus

1st Level Qualified SD: 5,000 DGSV X 20 X 5%	=	AUD 5,000
2nd Level Qualified SD: 5,000 DGSV X 400 X 10%	=	AUD 200,000
		<u><u>AUD 205,000</u></u>

7. Travel Seminar Incentive (2%)

The company will allocate 2% of company's Annual Sales in SV as the Travel Incentive Fund. It will be shared amongst the SA Qualifiers & SD Qualifiers and used to subsidise the travel seminar organised by the Company only.

Assumption:-

- Company Annual Sales is 9,000,000 SV.
- Travel Seminar Incentive Fund = 2% X 9,000,000 SV
= AUD180,000

A) Travel Seminar Incentive for SA Qualifiers.

Assumption:-

- i Total Accumulated TSIP for all SA Qualifiers is 400,000 points.
- ii YOUR Accumulated TSIP as a SA Qualifier is 6,000 points.
- iii Yearly TSIP QUOTA for SA is 5,000 points.
- iv Estimated cost of Travel Seminar for SA Qualifier is AUD750/pax.

Therefore:

Your Travel Seminar Incentive as SA Qualifier

$$= 50\% \times \text{AUD}180,000 \times \frac{6,000 \text{ pts}}{400,000 \text{ pts}} = \underline{\underline{\text{AUD}1,350}}$$

Note: Your TSI is more than enough to pay for one person to attend the Travel Seminar. So, you can either go for this Travel Seminar by yourself without any cash refund for the excess incentive or you may bring along your spouse by paying additional AUD150 as the short amount for the fare of two.

B) Travel Seminar Incentive for SD Qualifiers

Assumption:-

- i Total Accumulated TSIP for all SD Qualifiers is 500,000 points.
- ii Your Accumulated TSIP as a SD Qualifier is 14,000 points.
- iii Yearly TSIP QUOTA for SD is 12,500 points.
- iv Estimated cost of Travel Seminar for SD Qualifier is AUD1,250/pax.

Therefore:

Your Travel Seminar Incentive as SD Qualifier

$$= 50\% \times \text{AUD}180,000 \times \frac{14,000 \text{ pts}}{500,000 \text{ pts}} = \underline{\underline{\text{AUD}2,520}}$$

Note: Your TSI is more than enough to pay for two persons to attend the Travel Seminar. So, you can go for this Travel Seminar with your spouse. There is no cash refund for any excess incentive.

8. One Time Hand Phone Cash Incentive

EXAMPLE

After you have sponsored 3 immediate SA who achieved 3,000 Accumulated GPV.

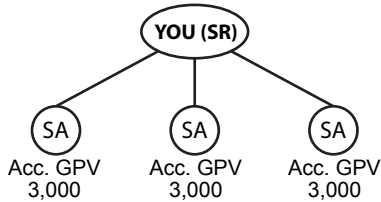

YOU are qualified to receive the One Time Hand Phone Cash Incentive amounting to AUD425.

9. One Time Overseas Trip Cash Incentive

EXAMPLE

After you have 5 immediate downlines who have received their Hand Phone Cash Incentive, Then you are qualified for this One Time Oversea Trip Cash Incentive.

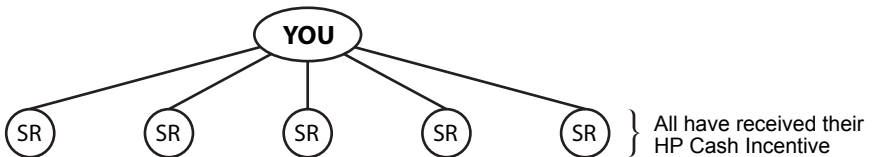

Therefore:

Once YOU have fulfilled the requirements, YOU are qualified for One Time Overseas Trip Cash Incentive amounting to AUD2,800.

How to become a Star Diamond within 5 months

Assumptions:-

- Personal Sales for each distributor is 50PPV per month.
- Each distributor sponsors 3 new distributors in each month.
- 1 PV = 1 SV

1st Month

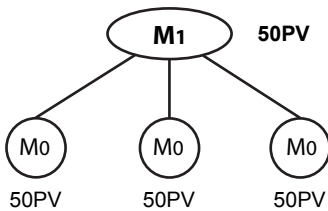

Your status : Distributor - 200PGPV (9%)

Personal PV/SV (PPV/PSV) = 50PV/SV
 Personal Group PV/SV (PGPV/PGSV) = 200PV/SV
 Accumulated PGPV = 200PV

Your Bonus Income		
Group Bonus	= 200SV X 9%	= AUD18
Less: Downlines Bonus	= (3 X 50SV X 6%)	=(AUD 9)
YOUR Bonus Income		<u><u>AUD 9</u></u>

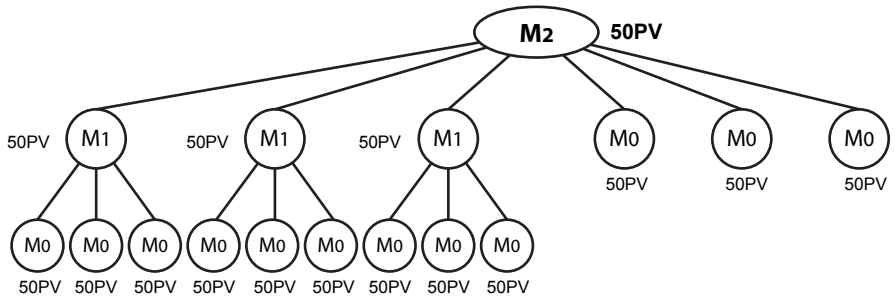

Your status : Distributor - Accumulated 1,000 PGPV (15%)

Personal PV/SV (PPV/PSV) = 50PV/SV
 Personal Group PV/SV (PGPV/PGSV) = 800PV/SV
 Accumulated PGPV b/f = 200PV
 Accumulated PGPV c/f = 1,000PV

Your Bonus Income

Group Bonus	= 800SV X 15%	= AUD120
Less: Downlines Bonus	= (200SV X 9% X 3) + (50SV X 6% X 3)	= (AUD 63)
YOUR Bonus Income		AUD 57

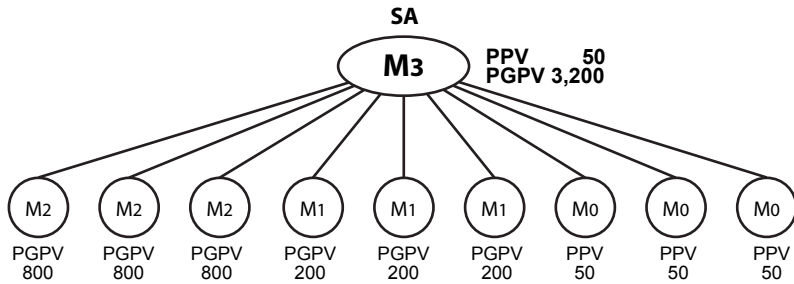

Congratulations! You have reached 2,250 Accumulated PGPV and you are now a Star Agent.

Personal PV/SV (PPV/PSV)	=	50PV/SV
Personal Group PV/SV (PGPV/PGSV)	=	3,200PV/SV
Accumulated PGPV b/f	=	1,000PV
Accumulated PGPV c/f	=	4,200PV

Your Bonus Income		
Group Bonus	=	3,200SV X 25% = AUD800
Less: Downlines Bonus	=	(800SV X 15% X 3)
	+	(200SV X 9% X 3)
	+	(50SV X 6% X 3) = (AUD423)

YOUR Bonus Income	<u><u>AUD377</u></u>
-------------------	----------------------

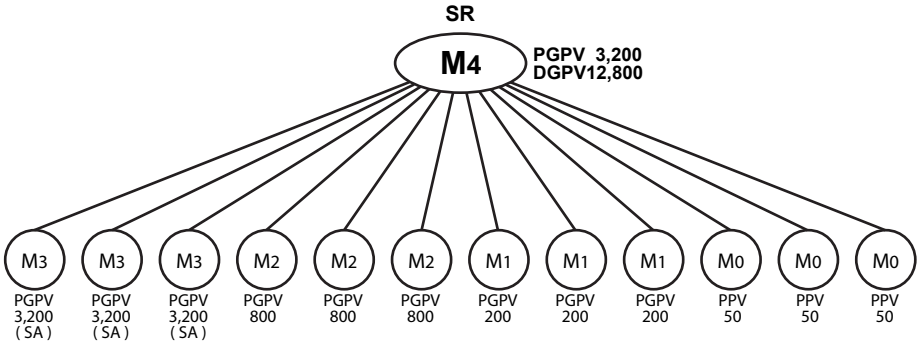

Congratulations! You have successfully promoted 3 direct Star Agent under you, and therefore you are now a Star Ruby.

Personal PV/SV (PPV/PSV) = 50PV/SV
 Personal Group PV/SV (PGPV/PGSV) = 3,200PV/SV
 Diamond Group PV/SV (DGPV/DGSV) = 12,800PV/SV

Your Bonus Income	=		=	
Star Group Bonus	=	12,800SV X 31%	=	AUD3,968
Less: Downlines Bonus	=	(3,200SV X 25% X 3)		
		+ (800SV X 15% X 3)		
		+ (200SV X 9% X 3)		
		+ (50SV X 6% X 3)	=	(AUD2,823)
				AUD1,145
Development Bonus	=	3,200SV X 5% X 3	=	AUD 480
HP Cash Incentive				AUD 425
Your Bonus Income				<u>AUD2,050</u>

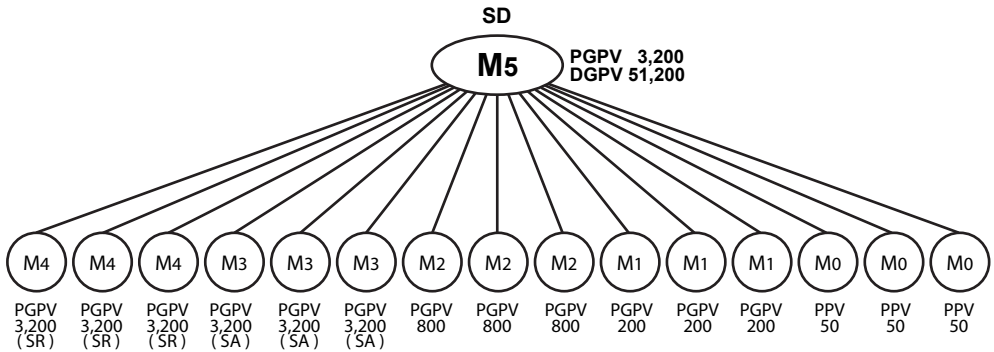

Congratulations! You have successfully promoted 6 SA (1st Generation) and have also met the 2,500DGPV quota. Hence you are now a Star Diamond.

Personal PV/SV (PPV/PSV) = 50PV/SV
 Personal Group PV/SV (PGPV/PGSV) = 3,200PV/SV
 Diamond Group PV/SV (DGPV/DGSV) = 51,200PV/SV

Your Bonus Income

(A) Star Group Bonus = 51,200SV X 37% = AUD18,944
 Less: Downlines Bonus = (12,800SV X 31% X 3)
 + (3,200SV X 25% X 3)
 + (800SV X 15% X 3)
 + (200SV X 9% X 3)
 + (50SV X 6% X 3) = (AUD14,727) **AUD4,217.00**

(B) Development Bonus
 1st Level = 3,200SV X 6 X 5% = AUD 960
 2nd Level = 3,200SV X 9 X 4% = AUD 1,152 **AUD2,112.00**

(C) International Profit Sharing
 Assumption:-
 i) IPS Fund = AUD20,000
 ii) Total IPS Point for all Qualifiers = 2,500,000pts
 iii) YOUR IPS Point for the month = 51,200SV X 100%
 = 51,200pts

Your International Profit Sharing

= AUD20,000 X $\frac{51,200pts}{2,500,000pts}$ = **AUD 409.60**

Your Bonus Income **AUD6,738.60**